

OPERATION MANUAL



SL- BC610



SL-BC610 15 Ton Streamline Compression Tool

Read and understand all of the instructions and safety information in this manual before operating or servicing this tool.



195 Internationale Blvd
Glendale Heights, IL 60139
Phone 800-860-6170
Fax 800-345-3767
www.spartacogroup.com

THANK YOU...

for purchasing a Huskie Tools product. Our mission is to supply the finest steel cable connecting and cutting tools and cable-related products to the transmission and distribution markets. Huskie Tools products represents the state-of-the-art tools and are dependable & safe. Trust, integrity, teamwork and mutual respect - these words are something we take to heart here at Huskie Tools.

Please take the time to read this manual carefully to learn how to correctly operate and maintain your tool.

Table of Contents

Registration/ Contents.....	2
Warranty.....	3
Safety.....	4
Kit Includes.....	5
Specifications.....	6
Operating Instructions.....	7
Operating Instructions (Part 2).....	8
Operating Precautions.....	9
Breakdown.....	10
Partslist.....	11
TroubleShooting Guide.....	12

Warranty

Huskie Tools products carry a warranty that makes us a leader in the tool industry. No other manufacturer dares to back its tools as we do.

All Huskie REC-SERIES battery operated products carry a 5 year warranty. The ECO-SERIES battery operated products carry a 1 year warranty. The BP-80 & BP-84 batteries carry a 5 year warranty from the date stamped on the battery. The BP-82 battery carries a 1 year warranty.

PRODUCT WARRANTY

REC-Series battery operated products	5 Years
ECO-Series battery operated products	1 Years
Batteries (BP-80, BP-84)	5 years/ (BP-82) 1 year
Chargers (CH-90, CH-94)	5 Years

The warranty does not cover any damages incurred from a Huskie tool including damages to property, bodily injuries and lost wages resulting from such injuries. This warranty solely covers the repair or replacement of tools supplied by Huskie. These remedies are exclusive, and the total liability of Huskie Tools, LLC whether based on contract, warranty, negligence, indemnification, strict liability or otherwise, shall not exceed the purchase price of the tool. In no event shall Huskie Tools, LLC be liable for consequential, incidental or special damages.

HUSKIE TOOLS, LLC MAKES NO OTHER WARRANTIES OF ANY KIND, EXPRESSED OR IMPLIED, AND ALL IMPLIED WARRANTIES INCLUDING ANY WARRANTY OF MERCHANTABILITY AND FITNESS FOR A PARTICULAR PURPOSE ARE DISCLAIMED.

Huskie reserves the right to determine all warranty claims. Huskie will not warranty tools containing parts or batteries not originally supplied by Huskie. Failure due to misuse, improper maintenance, misapplication, not following instructions or warnings, abuse or repairs attempted by anyone other than Huskie Tools, LLC, or an authorized service center renders this warranty null and void.

Repair and Warranty Claims

All claims must be sent to Huskie for inspection and authorization. A Return Goods Authorization (RGA) is required before shipping tools to Huskie. Secure the authorization by telephoning or writing to Huskie's main office with details of the claim. Non-warranty repairs are handled using the same procedure. Repairs exceeding 50 percent of the cost of a new tool will be advised before repairs are made.

Payment Terms

Upon credit approval Huskie's standard payment terms are net-30 days. Visa, Mastercard, Discover and American Express are also accepted.

Freight

All Huskie tools are FOB, Glendale Heights, Illinois. Goods will be shipped pre-paid and added, unless otherwise specified. Freight shipments over \$17,000 are pre-paid.

Quotations

Special quantity quotations should be phoned in to discuss the scope of your tool requests.

Complete Support Services

Our customers have direct access to us for training, service, and problem solving. As specialists in tools, we maintain a trained repair staff and a large stock of parts. This contrasts with many tool suppliers who carry tools as a sideline without offering support services. Here are some reasons why our customers love to do business with us:

- Quick delivery
- We maintain inventory at our headquarters.
- Training and troubleshooting services.
- Fast repair service.
- Design and engineering service for special tool needs.



Safety Alert Symbol:

This safety alert symbol indicates a potential personal injury hazard; it is not used for messages related to property damage only.



Wear eye protection:

when operating this tool. Failure to wear eye protection could result in serious eye injury from flying debris.



Electric Shock hazard:

Use proper personal protective equipment when using this unit on or near energized electrical lines.

Pinch Point Hazard:



Compression Dies at high force can cause severe personal injury. Keep all body parts away from moving parts of the tool while operating.



- 1 Battery Powered Tool
- 1 Carrying Case
- 1 CH-94 Charger
- 2 BP-84 Lithium Ion Batteries
- 1 Carrying Strap

Battery and Charger

- BP-84 Huskie Tools Lithium Ion Battery
- CH-94 Huskie Tools Charger
- This charger can charge the BP-84, BP-82 and BP-80 only. Huskie Tools batteries, including the BP-70, BP-70EI and the BP-70MH must be charged with the CH-90, CH-80, or previous charger models.



OPTIONAL ACCESSORIES:



The **SL-BC610** is built on a similar platform as our SL-ND tool, the most robust and versatile streamline tool in the industry. The new SL-BC610 will deliver 15 tons of compression force, utilizing all industry standard "P" dies. The capacity of the tool is the same as the REC-3610, capable of accepting lugs up to 1500MCM copper and 1250MCM Aluminum. The PU-15 die adapter is available for use with all 12 Ton "U" type dies.

Utilizing the streamline design and the traditional "C" head, the new SL-BC610 is one of the most versatile 15 ton tools in the market today. The new housing design incorporates a rubber over-mold handle grip as well an optional handle allowing the operator better tool control.

SL-BC610

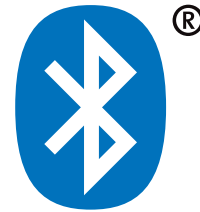

Specifications	
Output	15 Ton
Weight	20 lbs. with Battery
Size	23" L x 3.5" H x 4.5" W
Jaw Opening	2"
Crimping Estimates	
	BP-84
1000 MCM Cu	50
Connector Range	
Aluminum	#8 AWG - 1250 MCM
Copper	#8 AWG - 1500 MCM
H-Tap	Up to 750/750
Optional Accessories	
PU-15 "U" Die Adapter	

Features

- Utilizes "P" Type Dies
- Tested Up to 75kV
- Open C Head Design
- Rotational Head
- Rapid Advance
- Bright White, LED Lights for Working in Low Light Conditions
- Audible Bypass when Predetermined Pressure is Achieved
- Protective Rubber Boot on Head
- 5 Year Warranty on Tool, Battery & Charger

The new 6 series battery operated tools with "B" designation are Bluetooth enabled products. These tools are able to communicate data to your Bluetooth enabled PC via the downloadable software available on Spartaco website.

In addition to the audible beeps and visual Led indicators on these tools identifying battery connection, full compression cycles, proper achieved pressure, and incomplete crimps, the tools also record data to be viewed later via the Bluetooth connection at you PC.

The data includes locked fields for model and serial number of the tool connected. It has cycle count data, and it has fields for read / write capabilities for the user to enter notes such as truck or job number, repair history, or any note the user or maintenance technician may feel important to record.

Complete operation instructions as well as the downloadable computer software is available at: www.spartacogroup.com

CHARGING THE BATTERY

1. Insert the plug end into a 120V power source. The LED (Power) indicator will be steady green indicating the charger is now in “stand-by” mode and ready to charge the battery. Do not plug the charger into a generator as this will likely cause the fuse in the charger to short, and will not operate.
2. To charge a drained battery, insert the battery into the charger. The LED indicator shows a steady amber while charging. A depleted battery will be completely charged in approximately 50-70 minutes. The LED indicator will show a steady green when the battery is fully charged.
3. If the LED indicator goes out or is flashing quick amber, this could be a possible short in the battery circuit, or a problem with the charger itself. It is best to consult the factory at 1-800-860-6170 for service if such a condition occurs.
4. For technical questions or difficulty in operation, please call our customer service department at 1-800-860-6170.

ATTACHING THE BATTERY CARTRIDGE

1. While pressing the latch, pull out the battery cartridge. To replace the battery cartridge, push the new cartridge firmly into place.
2. After inserting a battery cartridge, check that it is securely in place by pulling gently. Do not press the latch when pulling the cartridge.

TRIGGER AND RELEASE BUTTON

1. The ram advances when the trigger is pressed and stops when the trigger is released.
2. To retract the ram, push the release button. The ram continues to retract while the release button is pressed.

COMPRESSION

1. Select the appropriate size dies for the connector being used.
2. Insert half of the die into the C-head until the die release push pin is securely locked into the die pin slots. Then insert the other half of the die into the ram until securely locked in place.
3. To open latch, pull lock pin and insert connector in tool head then close and push lock pin securely to tool head.
4. Press the trigger and advance the ram so the connector is held between the dies.
5. Insert the conductor into the connector.
6. Press the trigger until the compression is completed. A series of clicks will be heard followed by a release in pressure when compression is completed.
7. Press the release button to retract to ram. The ram continues to retract while the release button is pressed. The ram stops when it reaches the lower end.
8. Remove the conductor from the tool.

MAINTENANCE AND INSPECTION

1. Daily maintenance is required to ensure that the tool is kept in good working condition.
2. Check pressure of tool with factory approved pressure gage.
3. Do not store the tool in a humid environment.
4. Wipe away any excess oil with a soapy cloth.
5. Provided that maintenance of the tool is carried out regularly, the tool should provide many years of service.
6. Should you experience any difficulty with the operation and maintenance of this tool, contact Huskie's technical support department at 1-800-860-6170.

PRECAUTION FOR THE TOOL

1. Select appropriate dies for the connector to be compressed. Incorrect combinations result in inferior connections of the conductors. Consult your connector manufacturer for the recommended die/connector combinations.
2. Always point the tool AWAY from other people.
3. If the tool is stored for an extended period at a temperature of less than 25° F (-5°C), the tool should be allowed to return to room temperature to ensure smooth operation Use the tool only after it has been at room temperature for 1 hour.
4. Do not drop the tool. Dropping the tool may damage the hydraulic circuit and result in the tool not functioning correctly.
5. Keep the head and ram clean and free of debris. Solvents can be used to clean the head, but should not be used on the plastic body. Use soap and water to clean the body.
6. Do not use tool for continuous use. If any sign of over heating, allow the tool to cool for 15 mins.
7. Do not allow tool to be submerged in water. The tool may be used in damp or wet environments. However it is recommended for tool to be air-dried before use.

PRECAUTION FOR THE BATTERY CARTRIDGE

1. Do not short circuit the contacts or expose the cartridge to water, oil or solvents.
2. Do not disassemble or attempt to repair the battery cartridge or dispose of in a fire.
3. Do not drop or otherwise abuse the battery cartridge.
4. Do not leave the cartridge in locations where it will be exposed to a temperature greater than 140°F (60°C) for an extended period.
5. The battery has a limited life. When the crimping capacity becomes about 1/2 that of the original capacity, the battery should be replaced.
6. If the battery cartridge is stored without being charged, natural drainage will cause the power to be reduced. The battery should be charged every 3 months if not in use.

PRECAUTION FOR THE CHARGER

1. The LED indicator lights up amber and remains lit when the unit starts charging a battery cartridge. The indicator turns green when charging is completed.
2. The BP-84 can be charged with any of the Huskie Lithium-Ion chargers including the CH-80, CH-90 & CH-94.
3. Allow battery cartridges to cool before charging. Allow at least 15 minutes between charges when charging several cartridges in succession.
4. Charge batteries at an ambient temperature of 50°-95°F (10°-35° C). Charging time is approximately 50-70 minutes for the BP-84.
5. Never short circuit the output terminals.
6. Do not expose the charger to water, oil or solvents.
7. Do not disassemble, attempt to modify, drop or otherwise abuse charger.

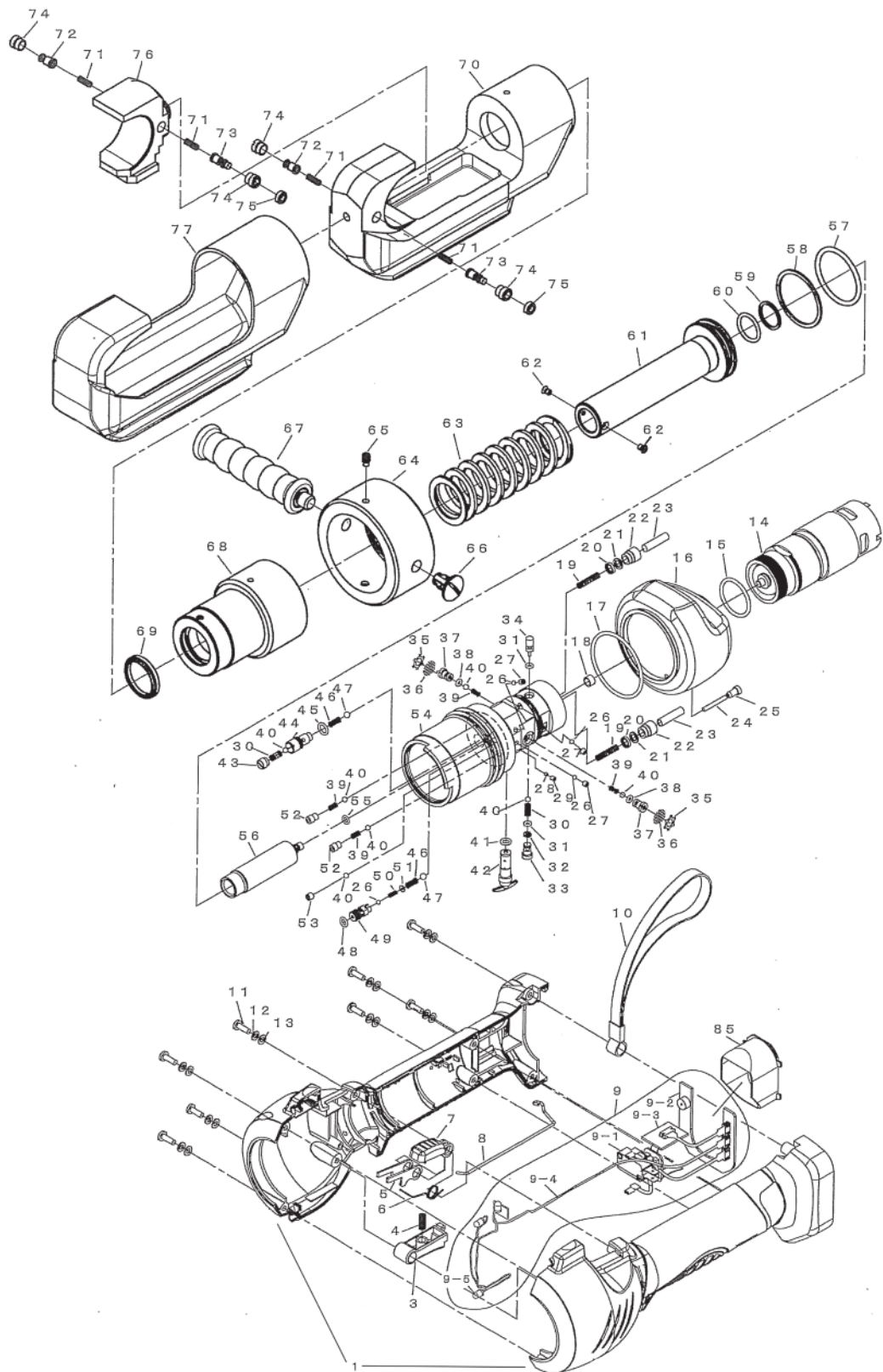

NO.	DESCRIPTION	CODE	QTY.
1	Housing blue/black Set	SL5-HS	1
3	Switch Knob	SLND-06	1
4	Spring(187)	40U-10	1
5	Lever Support	SLND-08	2
6	Spring(701)	SLND-09	1
7	Release Lever	SLND-07	1
8	Switch Rod	SLND-05	1
9	Switch Unit	SLND-04B	1
10	Strap	558-07	1
11	M4 X 10 Screw	ROB-159	8
12	M4 Lock Washer	EZ-37	8
13	M4 Flat Washer	EZ-36	8
14	Power Unit	SLND-11	1
15	G-30 O-Ring	75-26	1
16	Oil Reservoir(45)	SL5-13	1
17	G55 O-Ring	SL5-12	1
18	Bush	R14A-19	1
19	Spring (552)	EZ-16	2
20	PS-6 Pent Seal	EZ-14	2
21	P-6 Back-Up Ring (B.C.)	UC-28	2
22	Cylinder Insert	EZ-13	2
23	Pump Piston	EZ-15	2
24	Magnet	ROB-25	1
25	Plug	SLND-12	1
26	1/8" Ball	40-20	4
27	M4 X 4 Screw (F.P.)	85-47	3
28	Retainer	SLND-14	1
29	M3 X 5 Screw	UC-37A	1
30	Spring (689)	EZ-23	2
31	P-3 O-Ring	16-36	2
32	P-3 Back-Up Ring (B.C.)	9H-38	1
33	Release Plug	EZ-24	1
34	Release Valve Stem	EZ-17	1
35	SI-12.7 Ring	R14A-23	2
36	Filter Screen	R14A-22	2
37	Suction Valve	EZ-20	2
38	P-3 O-Ring (U801)	EZ-21	2
39	Spring (688)	EZ-22	4
40	5/32" Ball	22-21	7
41	P-5 O-Ring (B)	610F-18	1
42	Valve Cartridge	EZ-25K	1
43	Valve Screw	SL5-10	1
44	LP control plug	SL5-11	1
45	P-7 O-Ring	16-60	1
46	Spring (686)	EZ-26	2
47	3/16" Ball	16-49	2
48	P-5 O-Ring	5N-35	3

NO.	DESCRIPTION	CODE	QTY.
49	Both-way plug	SL5-18	1
50	Spring (420)	9H2-02	1
51	Stopper Ring	SL5-19	1
52	auto-suction screw	SL5-16	2
53	M5 X 5 Screw (F.P.)	510A-05	1
54	Body	SL6-01	1
55	S-5 O-Ring	351-20	1
56	Inner Pipe	361-02	1
57	P-44 O-Ring	610-14	1
58	P-44 Back-Up Ring (B.C.)	610-13	1
59	P-20 O-Ring	410-34	1
60	P-20 Back-Up Ring (B.C.)	35-18	1
61	Ram	BC610-04	1
62	Retaining Screw	3610-104	2
63	Ram Spring (622)	361-04	1
64	Collar	BC610-01	1
65	M6x10 Screw	BC610-02	1
66	Plug	SL6-03	1
67	Grip	R85-05	1
68	Cylinder	BC610-03	1
69	LPH-30 Dust Seal	451-05	1
70	Head	BC610-05	1
71	Spring (302)	610-06	4
72	Push Pin	610-05	2
73	Push Pin (B)	610-05B	2
74	Retaining Screw	610-04	4
75	Stopper Nut	610-27	2
76	Tool Jaw	BC610-06	1
77	Head Cover	BC610-07	1
85	Sleeve	BND-01	1
9-1	Main Switch Unit	BND-02	1
9-2	Circuit board(1)	BND-03	1
9-3	Circuit board(2)	BND-04	1
9-4	LED Harness (1)	BND-05	1
9-5	LED Harness (2)	BND-06	2

PROBLEM	CAUSE	SOLUTION
MOTOR RUNS, BUT THE TOOL JAWS WILL NOT ADVANCE	Insufficient Hydraulic Oil	Consult Factory for Repair Service
	Air Block in Hydraulic System	Invert tool to allow air to rise towards the top of the oil bladder
	Defective Hydraulic Circuit	Consult Factory for Repair Service
MOTOR RUNS, TOOL JAWS ADVANCE, BUT WILL NOT BUILD PRESSURE	Insufficient Hydraulic Oil	Consult Factory for Repair Service
	Defective Suction Valve or Bypass Cartridge	Consult Factory for Repair Service
MOTOR WILL NOT RUN AT ALL	Defective Battery	Charge or Replace Battery
	Bad Contact or Loose Battery Connections	Check all Connections and Wires
	Misaligned Switch	Check to Make Sure that Switch is Properly Aligned with Trigger
		Consult Factory for Repair Service
TOOL JAWS WILL NOT RELEASE	Tool Did Not Complete a Full Cycle and Bypass	Press Trigger and allow Tool to Bypass, Then Release Tool Jaws
	Connector is Jammed in Tool Jaws	Press and Hold Release Trigger While Prying Tool Jaws Apart
	Release Trigger is Bent or Misaligned	Consult Factory for Repair Service



NOTES



NOTES



NOTES



195 Internationale Blvd
Glendale Heights, IL 60139
Phone 800-860-6170
Fax 800-345-3767
www.spartacogroup.com